

HIGH INPUT VOLTAGE BUCK-BOOST CONVERTER WITH 2A SWITCH CURRENT

FEATURES

- Up to 93% Efficiency
- 2A/1A Output Current at 5V in Step Down Mode
- 1.3A Output Current at 5V in Boost Mode ($V_{IN} > 4V$)
- Automatic Transition Between Step Down and Boost Mode
- Typical Device Quiescent Current less than $30\mu A$
- Input Voltage Range: 2.5V to 12V
- Fixed and Adjustable Output Voltage Options from 2.5V to 8V
- Power Save Mode for Improved Efficiency at Low Output Power
- Forced Fixed Frequency Operation at 2.4MHz and Synchronization Possible
- Power Good Output
- Buck-Boost Overlap Control™
- Load Disconnect During Shutdown
- Overtemperature Protection
- Overvoltage Protection
- Available in a 3-mm × 3-mm, SON-10 Package

APPLICATIONS

- Dual Li-Ion Application
- DSC's and Camcorders
- Notebook Computer
- Industrial Metering Equipment
- Ultra Mobile PC's and Mobile Internet Devices
- Personal Medical Products
- High Power LED's

DESCRIPTION

The TPS6306x devices provide a power supply solution for products powered by either three-cell up to six-cell alkaline, NiCd or NiMH battery, or a one-cell or dual-cell Li-Ion or Li-polymer battery. Output currents can go as high as 2A while using a dual-cell Li-Ion or Li-Polymer Battery, and discharge it down to 5V or lower. The buck-boost converter is based on a fixed frequency, pulse-width-modulation (PWM) controller using synchronous rectification to obtain maximum efficiency. At low load currents, the converter enters Power Save mode to maintain high efficiency over a wide load current range. The Power Save mode can be disabled, forcing the converter to operate at a fixed switching frequency. The maximum average current in the switches is limited to a typical value of 2.5A. The output voltage is programmable using an external resistor divider, or is fixed internally on the chip. The converter can be disabled to minimize battery drain. During shutdown, the load is disconnected from the battery. The device is packaged in a 10-pin SON PowerPAD™ package measuring 3mm × 3mm (DSC).

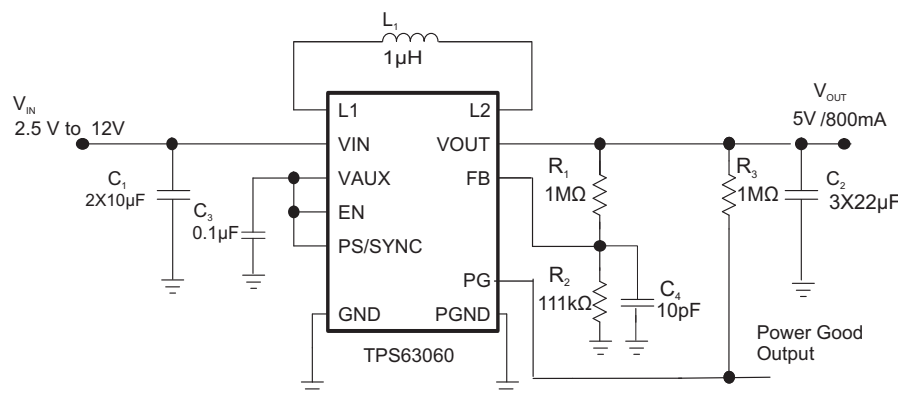

Please be aware that an important notice concerning availability, standard warranty, and use in critical applications of Texas Instruments semiconductor products and disclaimers thereto appears at the end of this data sheet.

Buck-Boost Overlap Control, PowerPAD are trademarks of Texas Instruments.



These devices have limited built-in ESD protection. The leads should be shorted together or the device placed in conductive foam during storage or handling to prevent electrostatic damage to the MOS gates.

AVAILABLE DEVICE OPTIONS⁽¹⁾

T _A	OUTPUT VOLTAGE DC/DC	PACKAGE MARKING	PACKAGE	PART NUMBER ⁽²⁾
-40°C to 85°C	Adjustable	QUJ	10-Pin SON	TPS63060DSC
	5 V	QUK		TPS63061DSC

(1) Contact the factory to check availability of other fixed output voltage versions.

(2) For detailed ordering information please check the PACKAGE OPTION ADDENDUM section at the end of this data sheet.

ABSOLUTE MAXIMUM RATINGS

over operating free-air temperature range (unless otherwise noted)⁽¹⁾

		VALUE		UNIT
		MIN	MAX	
Voltage range	V _{IN} , V _{OUT} , PS/SYNC, EN, FB	-0.3	17	V
	L1, L2	-0.3	V _{IN} +0.3	V
	FB, V _{AUX}	-0.3	7.5	V
Operating virtual junction temperature range, T _J		-40	150	°C
Storage temperature range T _{stg}		-65	150	°C
ESD rating ⁽²⁾	Human Body Model - (HBM)		3	kV
	Machine Model - (MM)		200	V
	Charge Device Model - (CDM)		1.5	kV

(1) Stresses beyond those listed under *absolute maximum ratings* may cause permanent damage to the device. These are stress ratings only, and functional operation of the device at these or any other conditions beyond those indicated under *recommended operating conditions* is not implied. Exposure to absolute-maximum-rated conditions for extended periods may affect device reliability.

(2) ESD testing is performed according to the respective JEDEC standard.

THERMAL INFORMATION

THERMAL METRIC ⁽¹⁾		TPS63060, TPS63061	UNITS
		DSC (10 PINS)	
θ _{JA}	Junction-to-ambient thermal resistance	48.7	°C/W
θ _{JC(TOP)}	Junction-to-case(top) thermal resistance	54.8	
θ _{JB}	Junction-to-board thermal resistance	19.8	
ψ _{JT}	Junction-to-top characterization parameter	1.1	
ψ _{JB}	Junction-to-board characterization parameter	19.6	
θ _{JC(BOTTOM)}	Junction-to-case(bottom) thermal resistance	4.2	

(1) For more information about traditional and new thermal metrics, see the *IC Package Thermal Metrics* application report, [SPRA953](#).

RECOMMENDED OPERATING CONDITIONS

	MIN	NOM	MAX	UNIT
Supply voltage at V _{IN}	2.5		12	V
Output Current I _{out} with V _{IN} = 10V to 12V			1	A
Operating free air temperature range, T _A	-40		85	°C
Operating virtual junction temperature range, T _J Output Current I _{out}	-40		125	°C

ELECTRICAL CHARACTERISTICS

over recommended free-air temperature range and over recommended input voltage range (typical at an ambient temperature range of 25°C) (unless otherwise noted)

PARAMETER		TEST CONDITIONS	MIN	TYP	MAX	UNIT	
DC/DC STAGE							
V_{IN}	Input voltage range		2.5		12	V	
V_{IIN}	Minimum input voltage for startup				2.5	V	
V_{OUT}	TPS63060 output voltage range		2.5		8	V	
	Minimum duty cycle in step down conversion			10%	20%		
V_{FB}	TPS63060 feedback voltage	PS/SYNC = V_{AUX}	495	500	505	mV	
	TPS63061 output voltage		4.95	5.0	5.05	V	
V_{FB}	TPS63060 feedback voltage	PS/SYNC = GND Referenced to 500mV	0.6%		5%		
	TPS63061 output voltage	PS/SYNC = GND Referenced to 5V	0.6%		5%		
f	Oscillator frequency		2200	2400	2600	kHz	
	Frequency range for synchronization		2200	2400	2600	kHz	
I_{SW}	Average inductance current limit	$V_{IN} = 5V, T_A = 25^\circ C$	2000	2250	2500	mA	
	High side switch on resistance	$V_{IN} = 5V$		90		m Ω	
	Low side switch on resistance	$V_{IN} = 5V$		95		m Ω	
	Line regulation	Power Save Mode disabled		0.5%			
	Load regulation	Power Save Mode disabled		0.5%			
I_q	Quiescent current	VIN	$I_O = 0\text{ mA}, V_{EN} = V_{IN} = V_{AUX} = 5V,$ $V_{OUT} = 5V$		30	60	μA
		VOU			7	15	μA
	TPS63061 FB input impedance	$V_{EN} = \text{HIGH}$		1.5		M Ω	
I_S	Shutdown current	$V_{EN} = 0\text{ V}, V_{IN} = V_{AUX} 5V$		0.3	2	μA	
CONTROL STAGE							
V_{AUX}	Maximum bias voltage	$V_{IN} > V_{OUT}$	V_{IN}		7	V	
		$V_{IN} < V_{OUT}$	V_{OUT}		7	V	
I_{AUX}	Load current at V_{AUX}				1	mA	
UVLO	Under voltage lockout threshold	V_{IN} voltage decreasing	1.8	1.9	2.2	V	
	UVLO hysteresis			300		mV	
V_{IL}	EN, PS/SYNC input low voltage				0.4	V	
V_{IH}	EN, PS/SYNC input high voltage		1.2			V	
	EN, PS/SYNC input current	Clamped on GND or V_{AUX}		0.01	0.1	μA	
	PG output low voltage	$V_{OUT} = 5V, I_{PGL} = 10\ \mu A$		0.04	0.4	V	
	PG output leakage current			0.01	0.1	μA	
	Output overvoltage protection		12		16	V	
	Overtemperature protection			140		$^\circ C$	
	Overtemperature hysteresis			20		$^\circ C$	

PIN ASSIGNMENTS

DSC PACKAGE
(TOP VIEW)

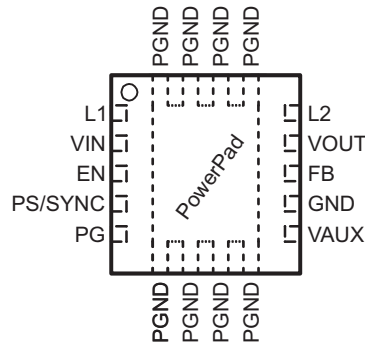

Pin Functions

NAME	PIN NO.	I/O	DESCRIPTION
EN	3	I	Enable input. (1 enabled, 0 disabled)
FB	8	I	Voltage feedback of adjustable versions, must be connected to VOUT on fixed output voltage versions
GND	7		Control / logic ground
L1	1	I	Connection for Inductor
L2	10	I	Connection for Inductor
PS/SYNC	4	I	Enable / disable power save mode (1 disabled, 0 enabled, clock signal for synchronization)
PG	5	O	Output power good (1 good, 0 failure; open drain)
PGND	PowerPAD™		Power ground
VIN	2	I	Supply voltage for power stage
VOUT	9	O	Buck-boost converter output
VAUX	6	I	Supply voltage for control stage
PowerPAD™			Must be soldered to achieve appropriate power dissipation. Must be connected to PGND.

FUNCTIONAL BLOCK DIAGRAM (TPS63060)

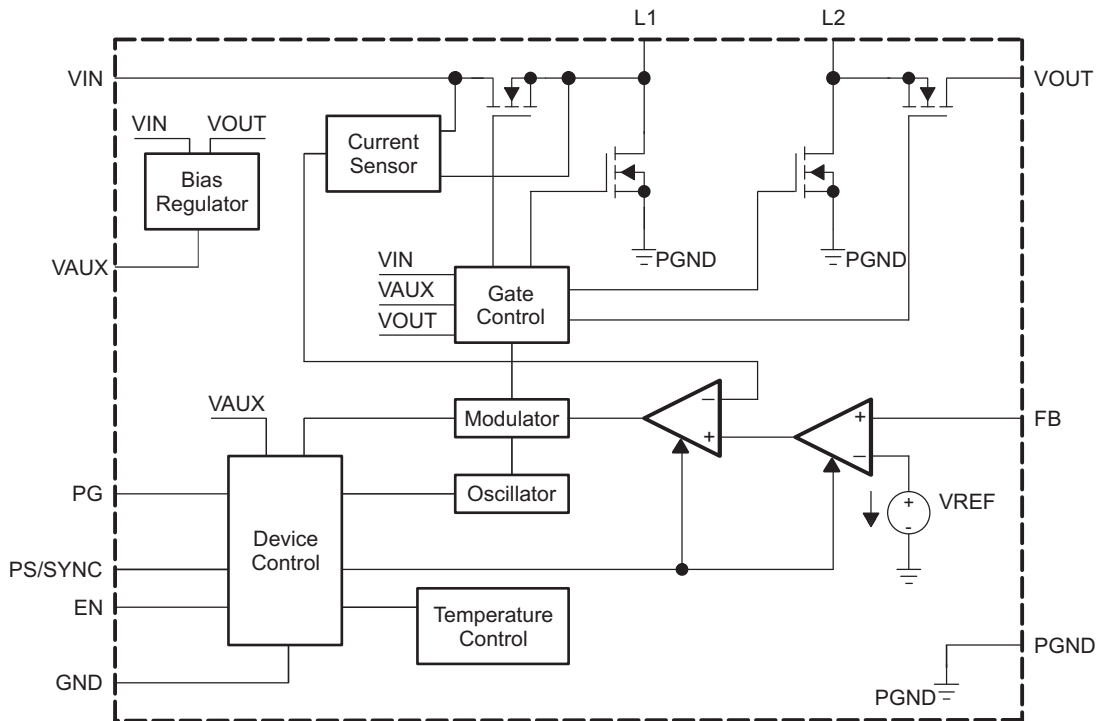

FUNCTIONAL BLOCK DIAGRAM (TPS63061)

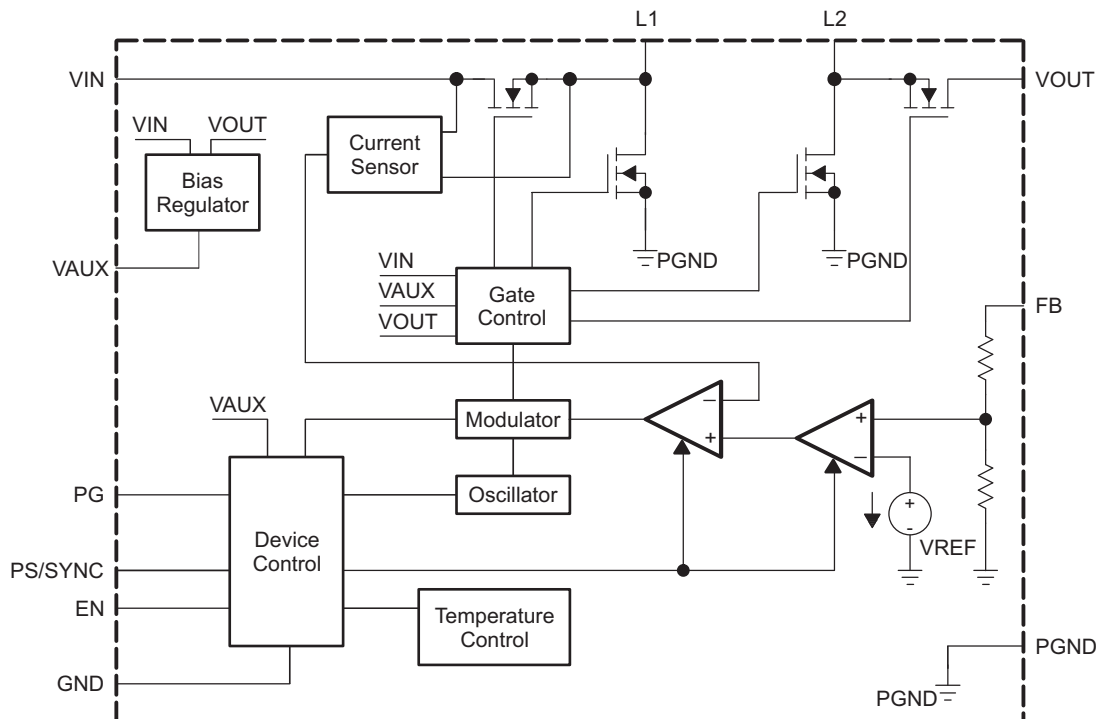

TYPICAL CHARACTERISTICS

TABLE OF GRAPHS

DESCRIPTION		FIGURE	
Maximum output current	vs Input voltage (TPS63060, VOUT = 2.5 V / VOUT = 8 V)	1	
	vs Input voltage (TPS63061, VOUT = 5V)	2	
Efficiency	vs Output current (TPS63060, Power Save Enabled, VOUT = 2.5 V / VOUT = 8 V)	3	
	vs Output current (TPS63060, Power Save Disabled, VOUT = 2.5V / VOUT = 8V)	4	
	vs Output current (TPS63061, Power Save Enabled, VOUT = 5V)	5	
	vs Output current (TPS63061, Power Save Disabled, VOUT = 5V)	6	
	vs Input voltage (TPS63060, Power Save Enabled, VOUT = 2.5V, IOU = {10; 500; 1000; 1300 mA})	7	
	vs Input voltage (TPS63060, Power Save Enabled, VOUT = 8V, IOU = {10; 500; 1000; 1300 mA})	8	
	vs Input voltage (TPS63060, Power Save Enabled, VOUT = 2.5V, IOU = {10; 500; 1000; 1300 mA})	9	
	vs Input voltage (TPS63060, Power Save Disabled, VOUT = 8V, IOU = {10; 500; 1000; 1300 mA})	10	
	vs Input voltage (TPS63061, Power Save Enabled, VOUT = 5V, IOU = {10; 500; 1000; 1300 mA})	11	
	vs Input voltage (TPS63061, Power Save Disabled, VOUT = 5V, IOU = {10; 500; 1000; 1300 mA})	12	
	Output voltage	vs Output current (TPS63060, VOUT = 2.5 V)	13
		vs Output current (TPS63060, VOUT = 8V)	14
vs Output current (TPS63061, VOUT = 5V)		15	
Waveforms	Load Transient response (TPS63061, Vin<Vout, Load Change from 600mA to 1A)	16	
	Load Transient response (TPS63061, Vin>Vout, Load change from 600mA to 1A)	17	
	Line Transient response (TPS63061, Vout=5V, Iout=500mA)	18	
	Startup after enable (TPS63061, Vout=5V, Vin=4.5V, Iout=1A)	19	
	Start up after enable (TPS63061, Vout=5V, Vin=8V, Iout=2A)	20	
	Load Transient response (TPS63060, Vin<Vout, Load change from 600mA to 1A)	21	
	Load Transient response, (TPS63060, Vin>Vout, Load change from 600mA to 1A)	22	
	Line Transient response (TPS63060, Vout=8V, Iout=500mA)	23	
	Start up after enable (TPS63060, Vout=8V, Vin< Vout, Vin=5V, Iout=1A)	24	
	Startup after enable (TPS63060, Vout=8V, Vin=12V, Iout=1A)	25	

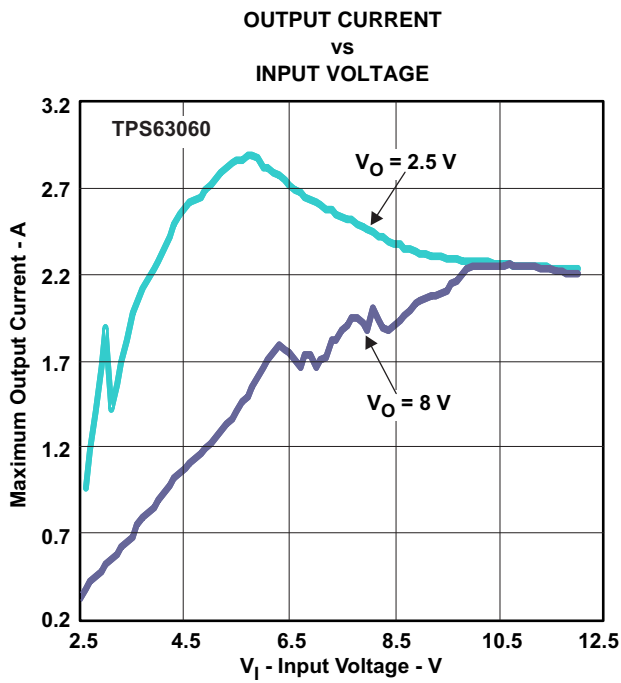

Figure 1.

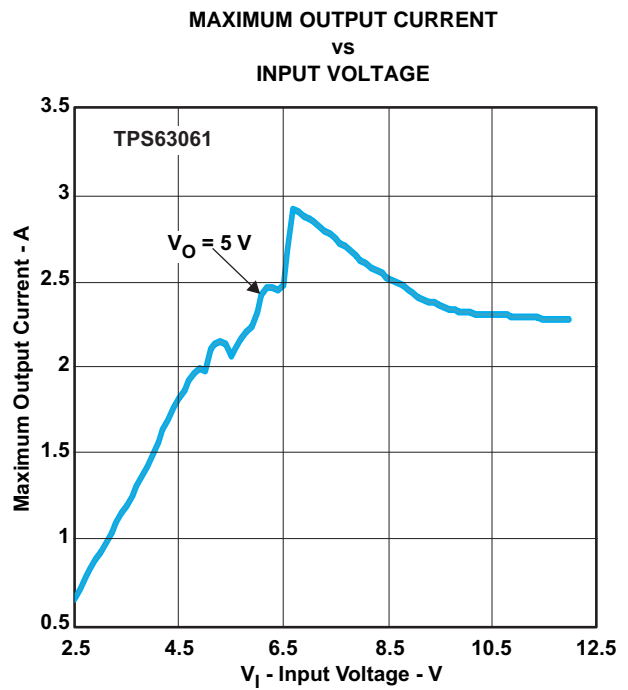

Figure 2.

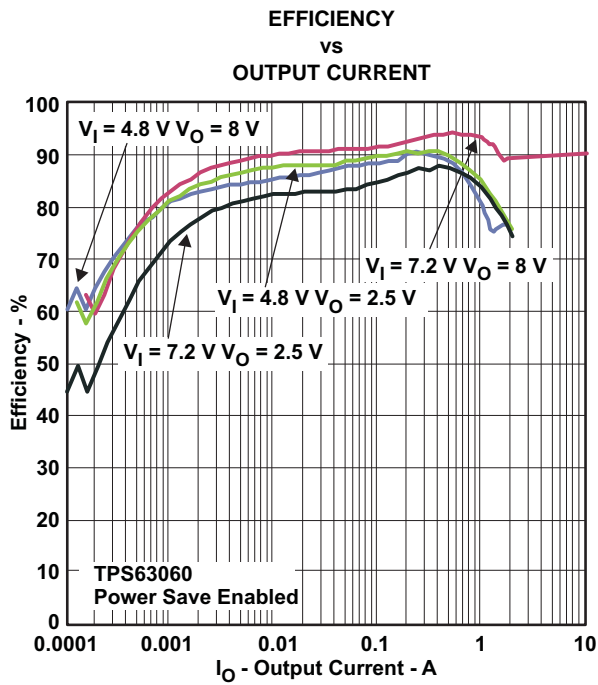

Figure 3.

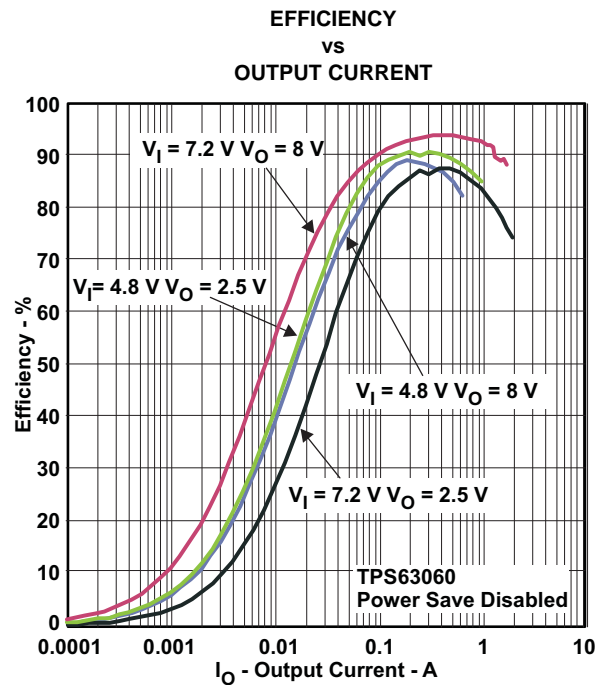

Figure 4.

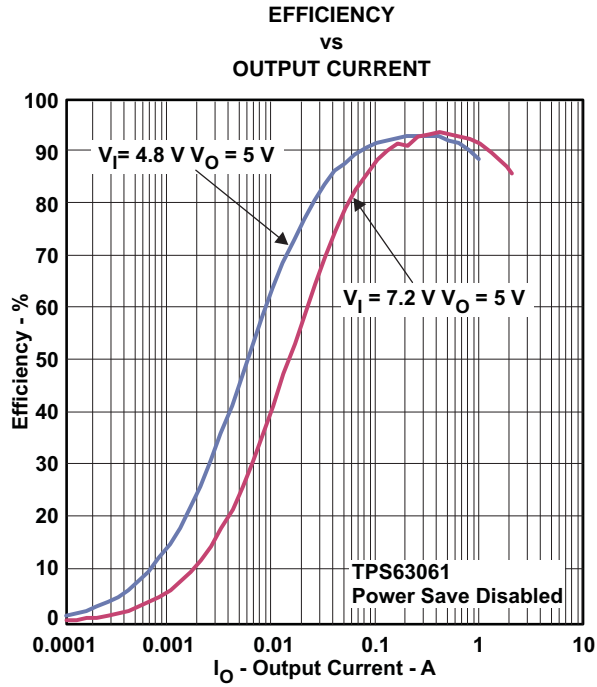

Figure 5.

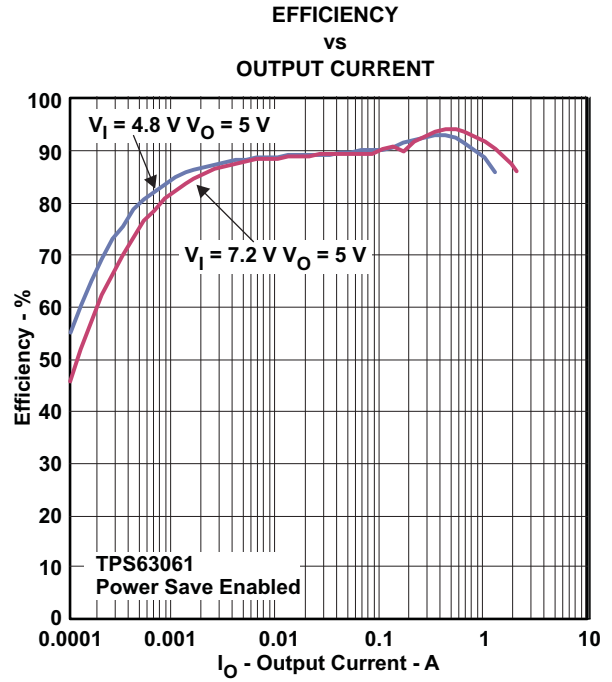

Figure 6.

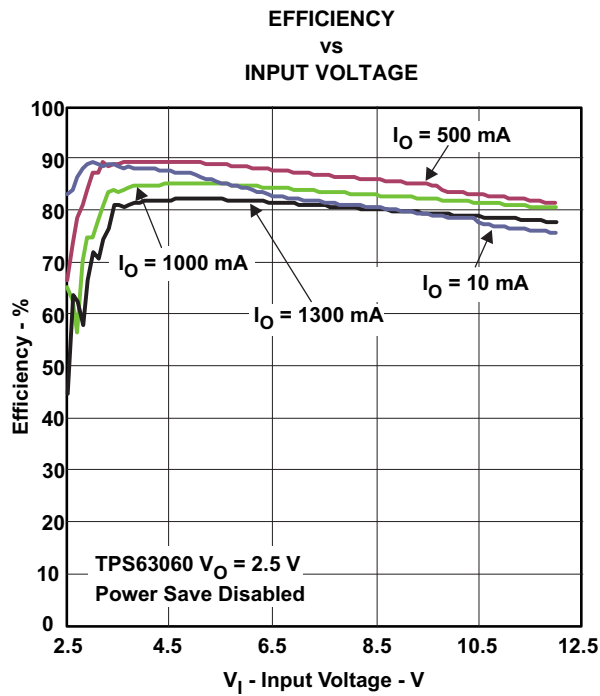

Figure 7.

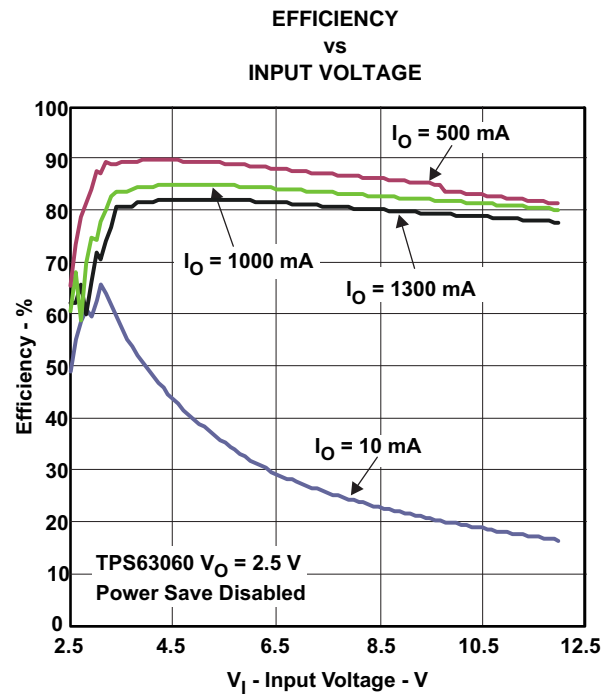

Figure 8.

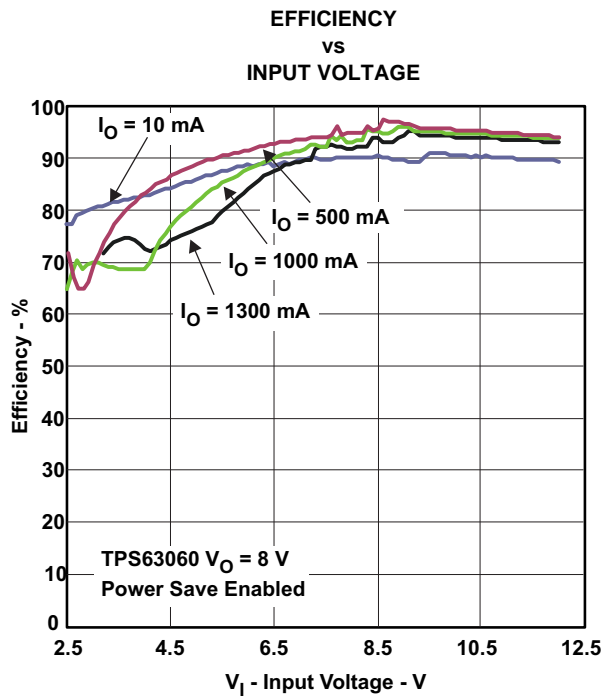

Figure 9.

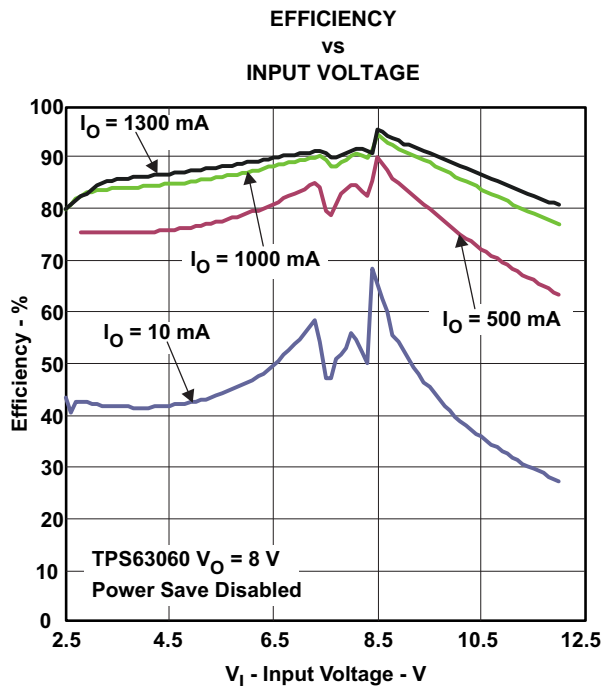

Figure 10.

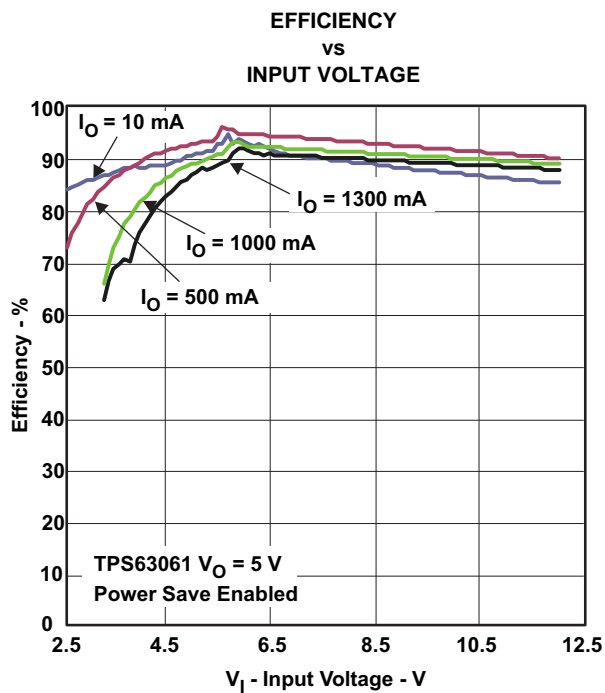

Figure 11.

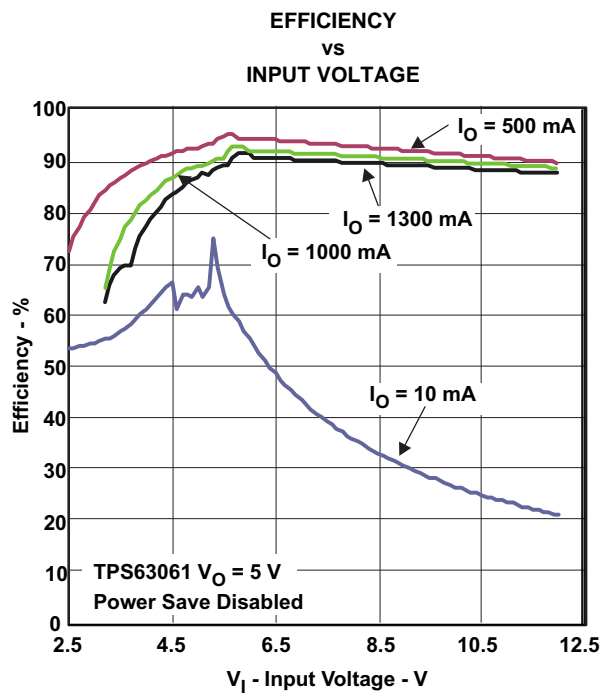
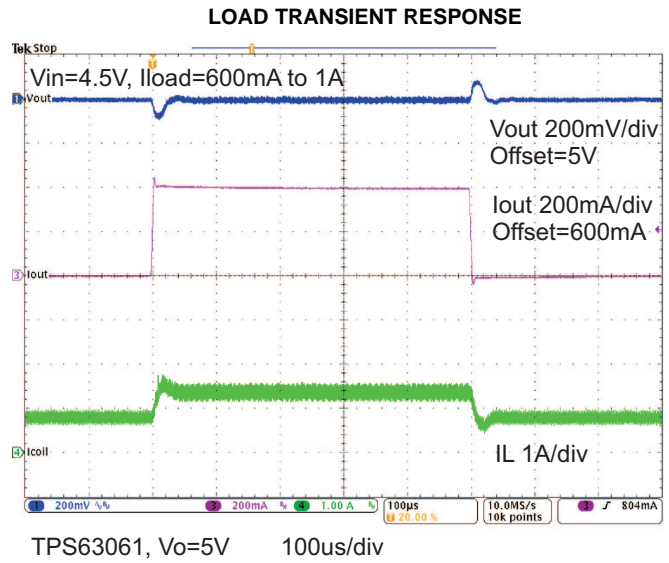
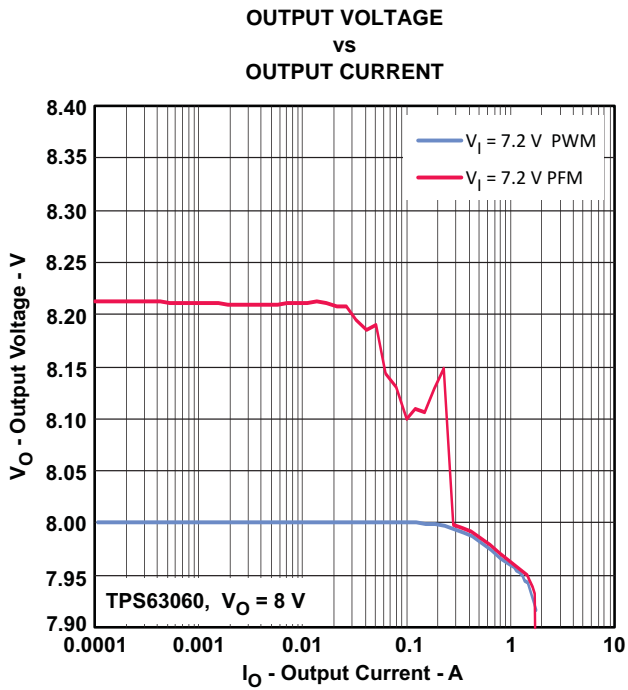
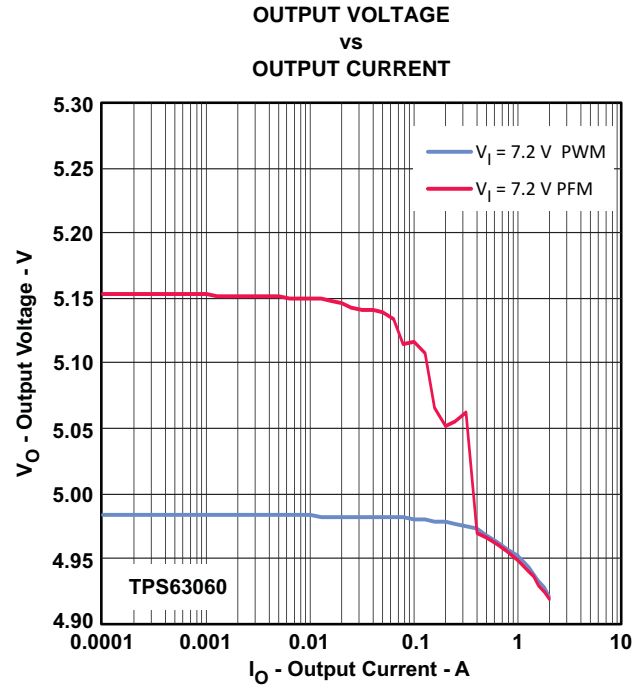
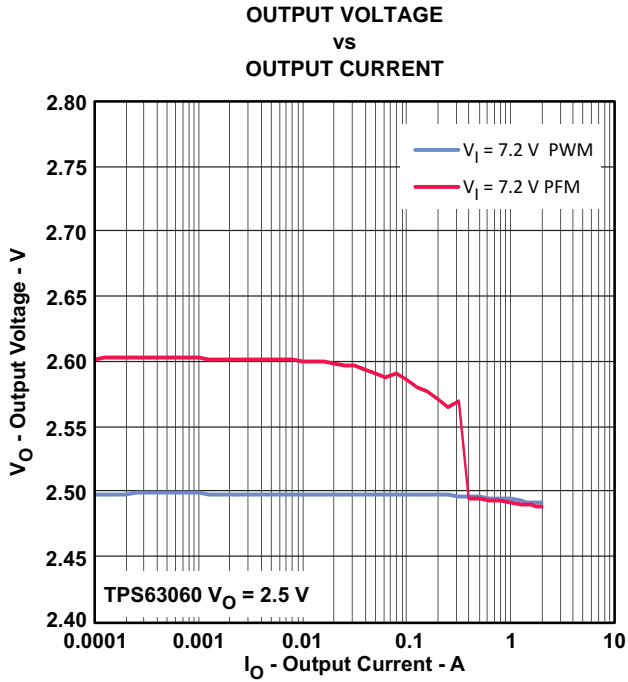
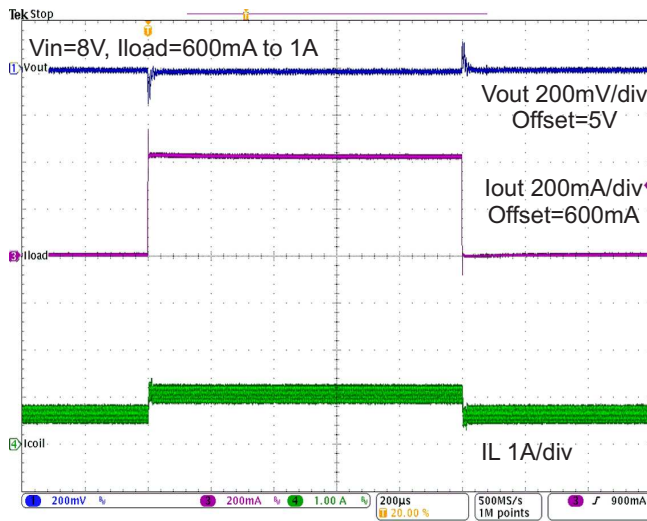

Figure 12.



LOAD TRANSIENT RESPONSE



TPS63061, Vo=5V 200µs/div

Figure 17.

LINE TRANSIENT RESPONSE

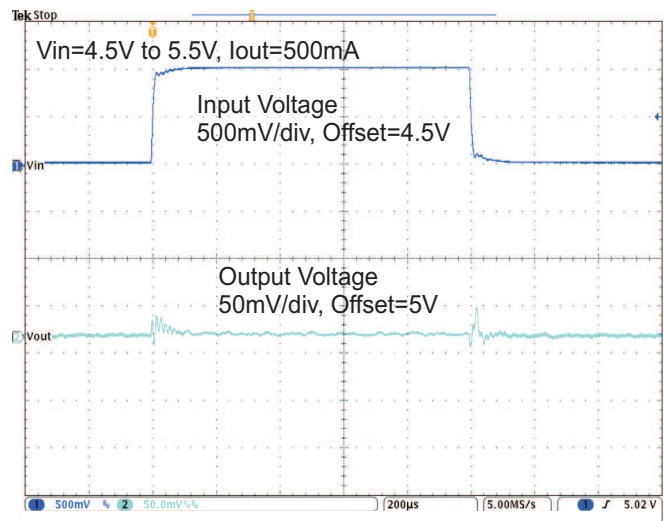

TPS63061, Vo=5V 200µs/div

Figure 18.

STARTUP AFTER ENABLE

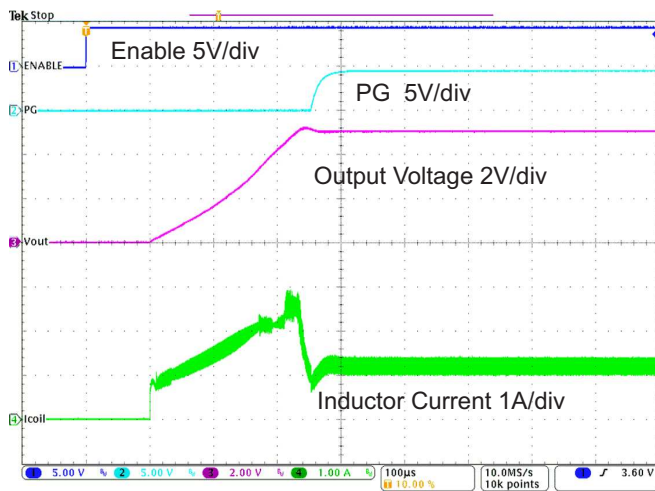

TPS63061, Vo=5V 100µs/div Vin=4.5V, Io=1A

Figure 19.

STARTUP AFTER ENABLE

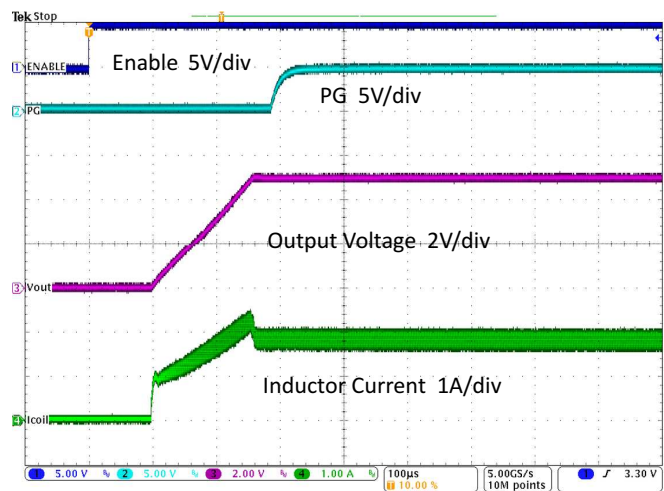

TPS63061, Vo=5V 100µs/div Vin=8V, Io=2A

Figure 20.

LOAD TRANSIENT

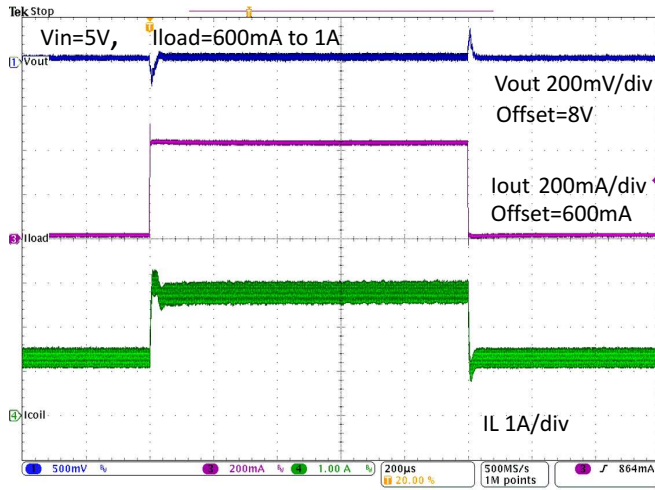

TPS63060, Vo=8V 200us/div

Figure 21.

LOAD TRANSIENT

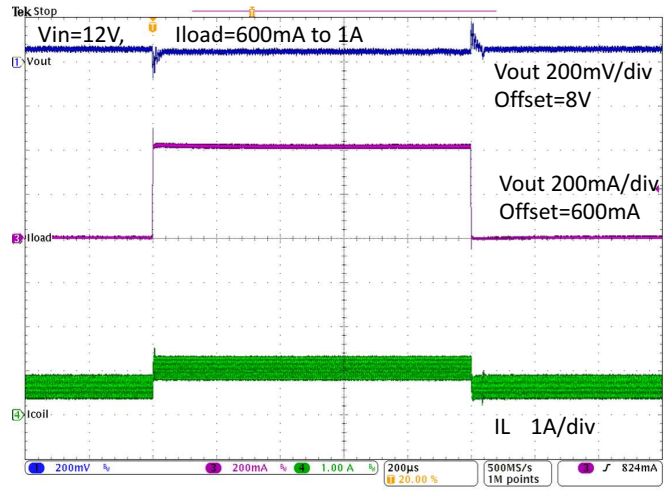

TPS63060, Vo=8V 200us/div

Figure 22.

LINE TRANSIENT

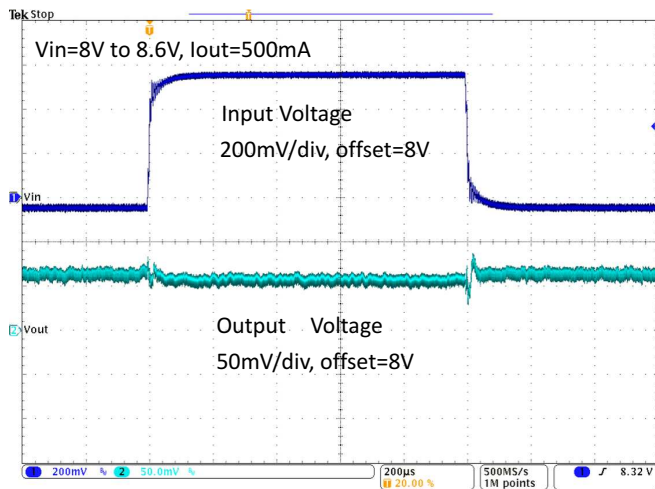

TPS63060 Vo=8V 200us/div

Figure 23.

STARTUP AFTER ENABLE

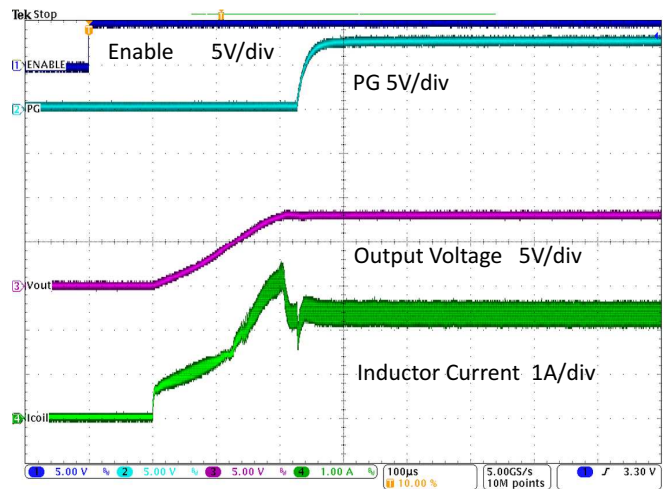

TPS63060, Vo=8V 100us/div Vin=5V, Io=1A

Figure 24.

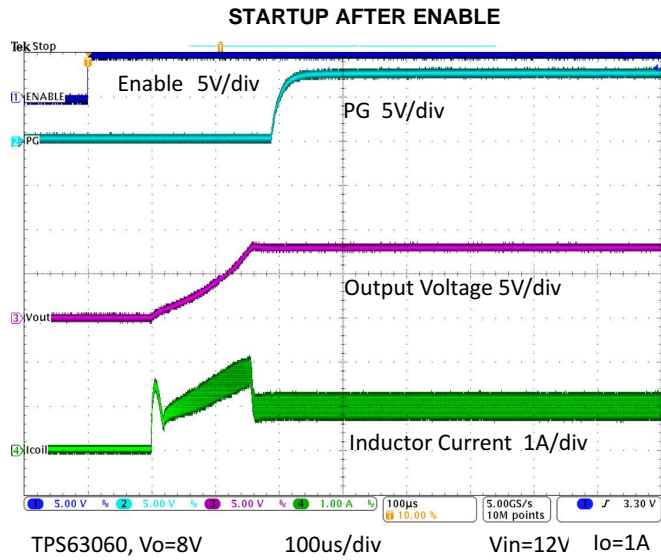

Figure 25.

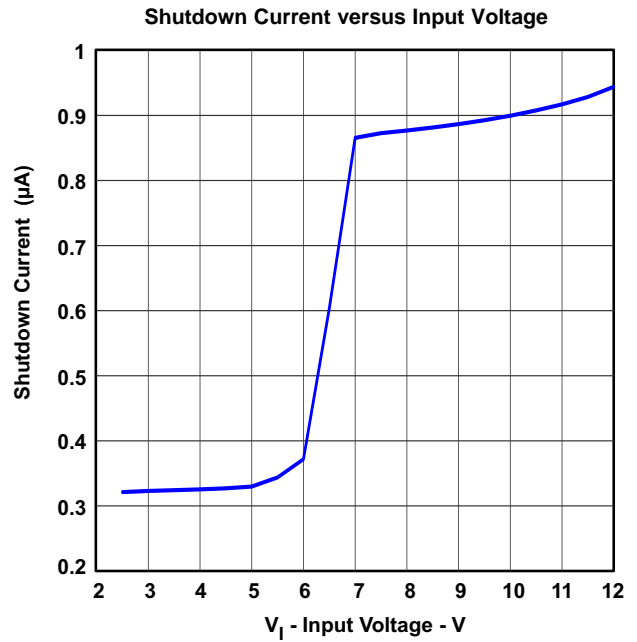

Figure 26.

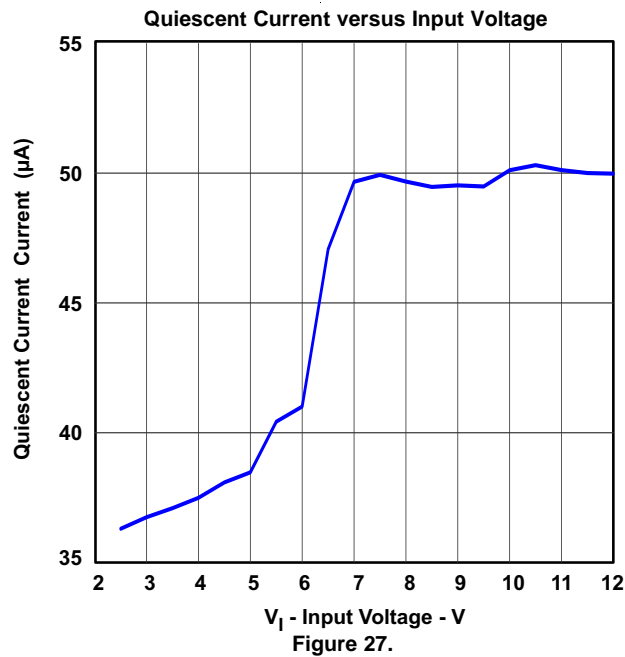

Figure 27.

PARAMETER MEASUREMENT INFORMATION

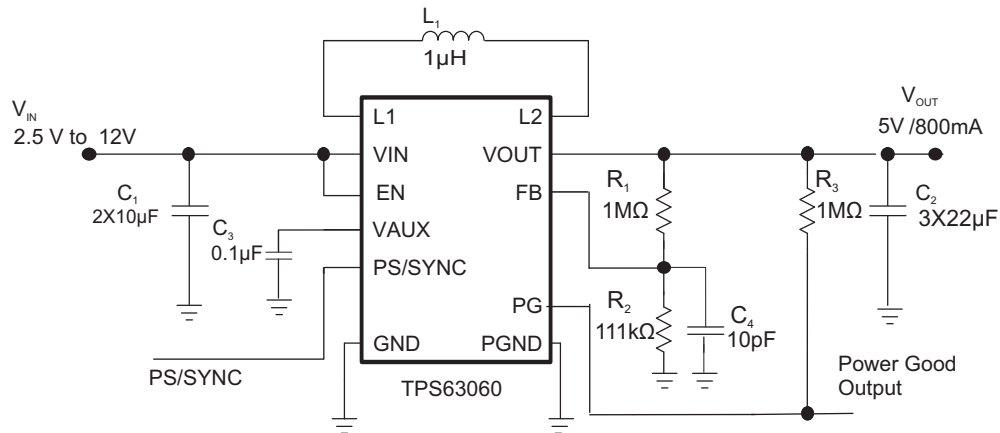

Table 1. List of Components

REFERENCE	DESCRIPTION	MANUFACTURER
	TPS63060	Texas Instruments
L1	1µH, 3 mm x 3 mm x 1.5 mm	Coilcraft , XFL4020-102
C1	10 µF 16V, 0805, X5R ceramic	Taiyo Yuden, EMK212BJ
C2	3 × 22 µF 16V, 0805, X5R ceramic	Taiyo Yuden, LMK212BJ
C3	0.1 µF, X5R ceramic	
C4	10pF, ceramic	
R1, R2	Depending on the output voltage at TPS63060 and TPS63061	

DETAILED DESCRIPTION

DETAILED DESCRIPTION

The controller circuit of the device is based on an average current mode topology. The controller also uses input and output voltage feedforward. Changes of input and output voltage are monitored and immediately can change the duty cycle in the modulator to achieve a fast response to those errors. The voltage error amplifier gets its feedback input from the FB pin. At adjustable output voltages, a resistive voltage divider must be connected to that pin. At fixed output voltages, FB must be connected to the output voltage to directly sense the voltage. Fixed output voltage versions use a trimmed internal resistive divider. The feedback voltage will be compared with the internal reference voltage to generate a stable and accurate output voltage.

The device uses 4 internal N-channel MOSFETs to maintain synchronous power conversion at all possible operating conditions. This enables the device to keep high efficiency over a wide input voltage and output power range. To avoid ground shift problems due to the high currents in the switches, two separate ground pins GND and PGND are used. The reference for all control functions is the GND pin. The power switches are connected to PGND. Both grounds must be connected on the PCB at only one point, ideally, close to the GND pin. Due to the 4-switch topology, the load is always disconnected from the input during shutdown of the converter. To protect the device from overheating an internal temperature sensor is implemented.

Buck-Boost Operation

To regulate the output voltage at all possible input voltage conditions, the device automatically switches from step down operation to boost operation and back as required. It always uses one active switch, one rectifying switch, one switch permanently on, and one switch permanently off. Therefore, it operates as a step down converter (buck) when the input voltage is higher than the output voltage, and as a boost converter when the input voltage is lower than the output voltage. There is no mode of operation in which all 4 switches are permanently switching. Controlling the switches this way allows the converter to maintain high efficiency at the most important point of operation, when the input voltage is close to the output voltage. The RMS current through the switches and the inductor is kept at a minimum, to minimize switching and conduction losses.

Control Loop Description

The average inductor current is regulated by a fast current regulator loop which is controlled by a voltage control loop. [Figure 28](#) shows the control loop.

The non inverting input of the transconductance amplifier G_{mv} can be assumed to be constant. The output of G_{mv} defines the average inductor current. The current through resistor R_S , which represents the actual inductor current, is compared to the desired value and the difference, or current error, is amplified and compared to the sawtooth ramp of either the Buck or the Boost.

The Buck-Boost Overlap Control™ makes sure that the classical buck-boost function, which would cause two switches to be on every half a cycle, is avoided. Thanks to this block whenever all switches becomes active during one clock cycle, the two ramps are shifted away from each other. However, when there is no switching activities because there is a gap between the ramps, the ramps are moved closer together. As a result the number of classical buck-boost cycles or no switching is reduced to a minimum and high efficiency values are achieved.

Slope compensation is not required to avoid subharmonic oscillation which are otherwise observed when working with peak current mode control with $D > 0.5$.

Nevertheless the amplified inductor current downslope at one input of the PWM comparator must not exceed the oscillator ramp slope at the other comparator input. This purpose is reached limiting the gain of the current amplifier.

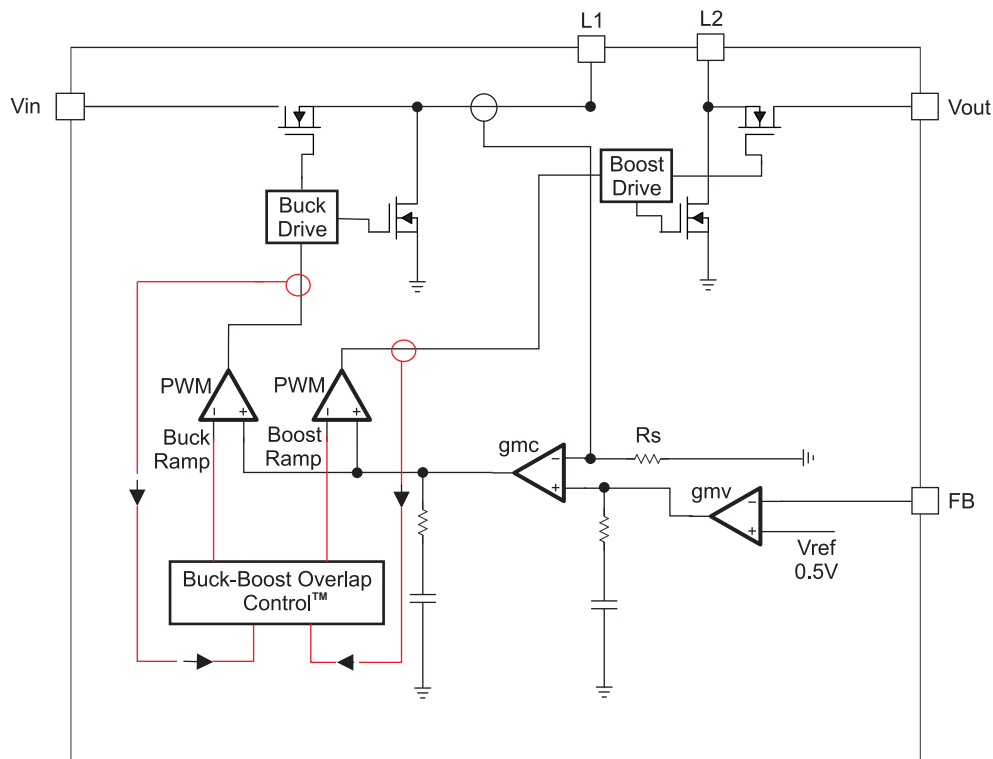

Figure 28. Average Current Mode Control

Power-save mode and synchronization

The PS/SYNC pin can be used to select different operation modes. Power Save Mode is used to improve efficiency at light load. To enable Power-Save, PS/SYNC must be set low. If PS/SYNC is set low then Power Save Mode is entered when the average inductor current gets lower than about 100mA. At this point the converter operates with reduced switching frequency and with a minimum quiescent current to maintain high efficiency.

During the Power Save Mode, the output voltage is monitored with a comparator by the threshold comp low and comp high. When the device enters Power Save Mode, the converter stops operating and the output voltage drops. The slope of the output voltage depends on the load and the value of output capacitance. As the output voltage falls below the comp low threshold set to 2.5% typical above V_{out} , the device ramps up the output voltage again, by starting operation using a programmed average inductor current higher than required by the current load condition. Operation can last for one or several pulses. The converter continues these pulses until the comp high threshold, set to typically 3.5% above V_{out} nominal, is reached and the average inductor current gets lower than about 100mA. When the load increases above the minimum forced inductor current of about 100mA, the device will automatically switch to PWM mode.

The Power Save Mode can be disabled by programming the PS/SYNC high. Connecting a clock signal at PS/SYNC forces the device to synchronize to the connected clock frequency.

Synchronization is done by a PLL to lower and higher frequencies compared to the internal clock. The PLL can also tolerate missing clock pulses without the converter malfunctioning. The PS/SYNC input supports standard logic thresholds.

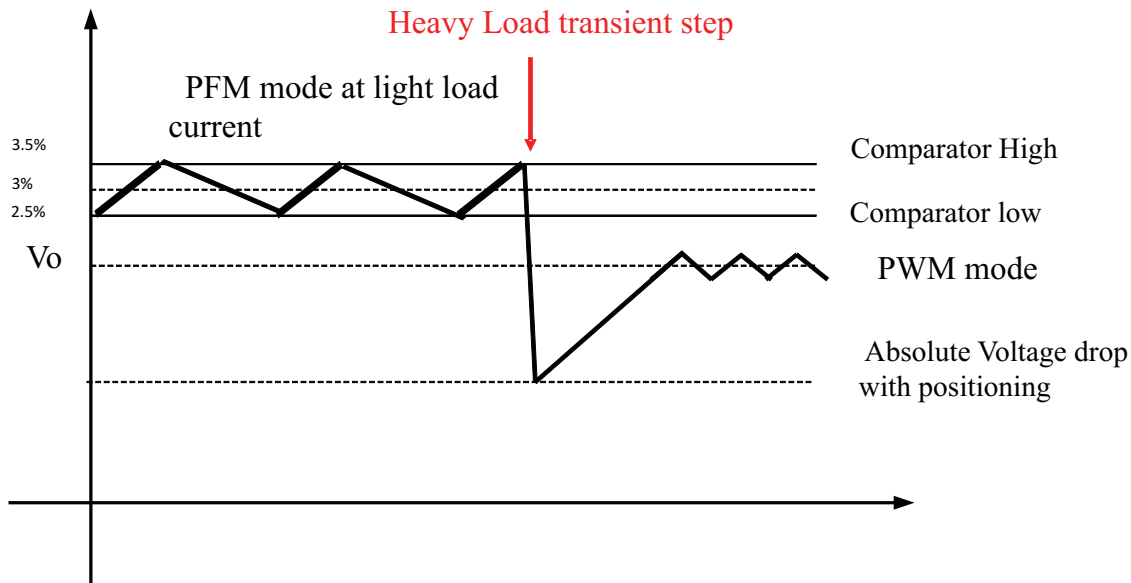

Figure 29. Power-Save Mode Thresholds and Dynamic Voltage Positioning

Dynamic voltage positioning

As detailed in Figure 29, the output voltage is typically 3% above the nominal output voltage at light load currents, as the device is in Power Save Mode. This gives additional headroom for the voltage drop during a load transient from light load to full load. This allows the converter to operate with a small output capacitor and still have a low absolute voltage drop during heavy load transient changes. See Figure 29 for detailed operation of the Power Save Mode

Dynamic Current limit

In order to keep the output voltage regulated when the power source becomes weaker the device has implemented a dynamic current limit function. The maximum current allowed through the switch depends on the voltage applied at the input terminal of the TPS6306X. The curve in Figure 30 shows this dependency, and the I_{SW} versus V_{IN} . The dynamic current limit has its lowest value when reaching the minimum recommended supply voltage at V_{IN} .

Given the I_{SW} value from Figure 30, is then possible to calculate the output current reached in boost mode using Equation 1 and Equation 2 and in buck mode using Equation 3 and Equation 4.

$$\text{Duty Cycle Boost} \quad D = \frac{V_{OUT} - V_{IN}}{V_{OUT}} \quad (1)$$

$$\text{Maximum Output Current Boost} \quad I_{OUT} = \eta \times I_{SW} \times (1 - D) \quad (2)$$

$$\text{Duty Cycle Buck} \quad D = \frac{V_{OUT}}{V_{IN}} \quad (3)$$

$$\text{Maximum Output Current Buck} \quad I_{OUT} = I_{SW} - \frac{(V_{IN} - V_{OUT}) \times D}{2 \times L \times f} \quad (4)$$

With,

η = Estimated converter efficiency (use the number from the efficiency curves or 0.80 as an assumption)

f = Converter switching frequency (typical 2.4 MHz)

L = Selected inductor value

If the die temperature increases above the recommended maximum temperature, the dynamic current limit becomes active. The current limit is reduced with temperature increasing.

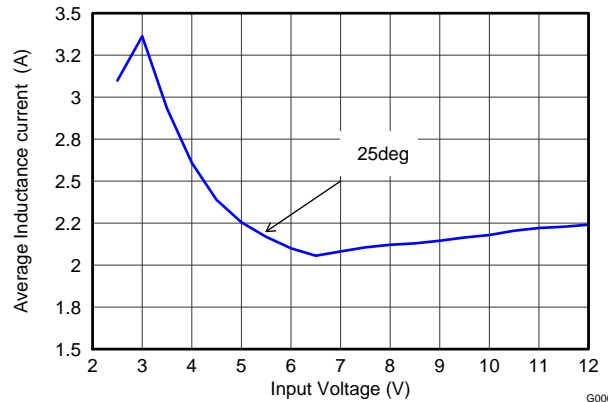

Figure 30. Average Inductance Current versus Input Voltage

Device Enable

The device is put into operation when EN is set high. It is put into a shutdown mode when EN is set to GND. In shutdown mode, the regulator stops switching, all internal control circuitry is switched off, and the load is disconnected from the input. This means that the output voltage can drop below the input voltage during shutdown. During start-up of the converter, the duty cycle and the peak current are limited in order to avoid high peak currents flowing from the input.

Power Good

The device has a built in power good function to indicate whether the output voltage is regulated properly. As soon as the average inductor current gets limited to a value below the current the voltage regulator demands for maintaining the output voltage the power good output gets low impedance. The output is open drain, so its logic function can be adjusted to any voltage level the connected logic is using, by connecting a pull up resistor to the supply voltage of the logic. By monitoring the status of the current control loop, the power good output provides the earliest indication possible for an output voltage break down and leaves the connected application a maximum time to safely react.

Softstart and Short Circuit Protection

After being enabled, the device starts operating. The average current limit ramps up from an initial 400mA following the output voltage increasing. At an output voltage of about 1.2V, the current limit is at its nominal value. If the output voltage does not increase, the current limit will not increase. There is no timer implemented. Thus, the output voltage overshoot at startup, as well as the inrush current, is kept at a minimum. The device ramps up the output voltage in a controlled manner even if a large capacitor is connected at the output. When the output voltage does not increase above 1.2V, the device assumes a short circuit at the output, and keeps the current limit low to protect itself and the application. At a short on the output during operation, the current limit is also kept under 2A typically (minimum average inductance current).

Overvoltage Protection

If, for any reason, the output voltage is not fed back properly to the input of the voltage amplifier, control of the output voltage will not work anymore. Therefore, overvoltage protection is implemented to avoid the output voltage exceeding critical values for the device and possibly for the system it is supplying. The implemented overvoltage protection circuit monitors the output voltage internally as well. If it reaches the overvoltage threshold, the voltage amplifier regulates the output voltage to this value.

Undervoltage Lockout

An undervoltage lockout function prevents device start-up if the supply voltage on VAUX is lower than approximately its threshold (see the *Electrical Characteristics* table). When in operation, the device automatically enters the shutdown mode if the voltage on VAUX drops below the undervoltage lockout threshold. The device automatically restarts if the input voltage recovers to the minimum operating input voltage.

Overtemperature Protection

The device has a built-in temperature sensor which monitors the internal IC temperature. If the temperature exceeds the programmed threshold (see the *Electrical Characteristics* table) the device stops operating. As soon as the IC temperature has decreased below the programmed threshold, it starts operating again. There is a built-in hysteresis to avoid unstable operation at IC temperatures at the overtemperature threshold.

APPLICATION INFORMATION

DESIGN PROCEDURE

The TPS6306x series of buck-boost converter has internal loop compensation. Therefore, the external L-C filter has to be selected to work with the internal compensation. When selecting the output filter a low limit for the inductor value exists to avoid subharmonic oscillation which could be caused by a far too fast ramp up of the amplified inductor current. For the TPS6306x series, the minimum inductor value should be kept at 1µH. Selecting a larger output capacitor value is less critical because the corner frequency moves to lower frequencies causing fewer stability problems. To simplify this process, [Table 2](#) outlines possible inductor and capacitor value combinations.

Table 2. Output Filter Selection (Average Inductance current up to 2A)

INDUCTOR VALUE [µH] ⁽¹⁾	OUTPUT CAPACITOR VALUE [µF] ⁽²⁾		
	44	66	100
1.0	√	√ ⁽³⁾	√
1.5	√	√	√

- (1) Inductor tolerance and current de-rating is anticipated. The effective inductance can vary by 20% and –30%.
- (2) Capacitance tolerance and bias voltage de-rating is anticipated. The effective capacitance can vary by 20% and –50%.
- (3) Typical application. Other check mark indicates recommended filter combinations

Inductor Selection

For high efficiencies, the inductor should have a low dc resistance to minimize conduction losses. Especially at high-switching frequencies the core material has a higher impact on efficiency. When using small chip inductors, the efficiency is reduced mainly due to higher inductor core losses. This needs to be considered when selecting the appropriate inductor. The inductor value determines the inductor ripple current. The larger the inductor value, the smaller the inductor ripple current and the lower the conduction losses of the converter. Conversely, larger inductor values cause a slower load transient response. To avoid saturation of the inductor, with the chosen inductance value, the peak current for the inductor in steady state operation can be calculated. [Equation 1](#) and [Equation 5](#) show how to calculate the peak current I_{PEAK}. Only the equation which defines the switch current in boost mode is reported because this is providing the highest value of current and represents the critical current value for selecting the right inductor.

$$I_{PEAK} = \frac{I_{out}}{\eta \times (1 - D)} + \frac{V_{in} \times D}{2 \times f \times L} \quad (5)$$

With,

D = Duty Cycle in Boost mode

f = Converter switching frequency (typical 2.4 MHz)

L = Selected inductor value

η = Estimated converter efficiency (use the number from the efficiency curves or 0.80 as an assumption)

Note: The calculation must be done for the minimum input voltage which is possible to have in boost mode

Consideration must be given to the load transients and error conditions that can cause higher inductor currents. This must be taken into consideration when selecting an appropriate inductor. See [Table 3](#) for typical inductors.

The size of the inductor can also affect the stability of the feedback loop. In particular the boost transfer function exhibits a right half-plane zero, whose frequency is inverse proportional to the inductor value and the load current. This means higher is the value of inductance and load current more possibilities has the right plane zero to be moved at lower frequency. This could degrade the phase margin of the feedback loop. It is recommended to choose the inductor's value in order to have the frequency of the right half plane zero >400KHz. The frequency of the RHPZ can be calculated using [Equation 6](#).

$$f_{RHPZ} = \frac{(1 - D)^2 \times V_{out}}{2\pi \times I_{out} \times L} \quad (6)$$

With,

D =Duty Cycle in Boost mode

Note: The calculation must be done for the minimum input voltage which is possible to have in boost mode

Table 3. Inductor Selection

INDUCTOR VALUE	COMPONENT SUPPLIER	SIZE (LxWxH mm)	Isat/DCR
1 μ H	Coilcraft XFL4020-102	4 x 4 x 2.1	5.1A/10.8 m Ω
1 μ H	TOKO DEM2815 1226AS-H-1R0N	3 x 3.2 x 1.5	2.7A/27 m Ω
1.5 μ H	Coilcraft XFL4020-152	4 x 4 x 2.1	4.4A/ 14.40m Ω

Capacitor selection

Input Capacitor

At least a 10 μ F input capacitor is recommended to improve transient behavior of the regulator and EMI behavior of the total power supply circuit. A ceramic capacitor placed as close as possible to the VIN and PGND pins of the IC is recommended.

Output Capacitor

For the output capacitor, use of a small ceramic capacitors placed as close as possible to the VOUT and PGND pins of the IC is recommended. If, for any reason, the application requires the use of large capacitors which can not be placed close to the IC, use a smaller ceramic capacitor in parallel to the large capacitor. The small capacitor should be placed as close as possible to the VOUT and PGND pins of the IC. The recommended typical output capacitor value is 66 μ F with a variance as outlined in [Table 2](#).

There is also no upper limit for the output capacitance value. Larger capacitors will cause lower output voltage ripple as well as lower output voltage drop during load transients.

When choosing input and output capacitors, it needs to be kept in mind, that the value of capacitance experiences significant losses from their rated value depending on the operating temperature and the operating DC voltage. It's not uncommon for a small surface mount ceramic capacitor to lose 50% and more of it's rated capacitance. For this reason, it is important to use a larger value of capacitance or a capacitor with higher voltage rating in order to ensure the required capacitance at the full operating voltage.

Bypass Capacitor

To make sure that the internal control circuits are supplied with a stable low noise supply voltage, a capacitor is connected between VAUX and GND. Using a ceramic capacitor with a value of 0.1 μ F is recommended. The value of this capacitor should not be higher than 0.22 μ F.

Setting the Output Voltage

When the adjustable output voltage version TPS63060 is used, the output voltage is set by the external resistor divider. The resistor divider must be connected between VOUT, FB and GND. When the output voltage is regulated properly, the typical value of the voltage at the FB pin is 500mV. The maximum recommended value for the output voltage is 8V. The current through the resistive divider should be about 100 times greater than the current into the FB pin. The typical current into the FB pin is 0.01 μ A, and the voltage across the resistor between FB and GND, R₂, is typically 500 mV. Based on these two values, the recommended value for R₂ should be lower than 500k Ω , in order to set the divider current at 3 μ A or higher. It is recommended to keep the value for this resistor in the range of 200k Ω . From that, the value of the resistor connected between VOUT and FB, R₁, depending on the needed output voltage (V_{OUT}), can be calculated using [Equation 7](#):

$$R1 = R2 \times \left(\frac{V_{OUT}}{V_{FB}} - 1 \right) \quad (7)$$

A small capacitor C₄=10pF, in parallel with R₂ needs to be placed when using the Power Save Mode and the adjustable version, to provide filtering and improve the efficiency at light load.

LAYOUT CONSIDERATIONS

For all switching power supplies, the layout is an important step in the design, especially at high peak currents and high switching frequencies. If the layout is not carefully done, the regulator could show stability problems as well as EMI problems. Therefore, use wide and short traces for the main current path and for the power ground tracks. The input capacitor, output capacitor, and the inductor should be placed as close as possible to the IC. Use a common ground node for power ground and a different one for control ground to minimize the effects of ground noise. Connect these ground nodes at any place close to one of the ground pins of the IC.

The feedback divider should be placed as close as possible to the control ground pin of the IC. To lay out the control ground, short traces are recommended as well, separation from the power ground traces. This avoids ground shift problems, which can occur due to superimposition of power ground current and control ground current.

THERMAL INFORMATION

Implementation of integrated circuits in low-profile and fine-pitch surface-mount packages typically requires special attention to power dissipation. Many system-dependent issues such as thermal coupling, airflow, added heat sinks and convection surfaces, and the presence of other heat-generating components affect the power-dissipation limits of a given component.

Three basic approaches for enhancing thermal performance are listed below.

- Improving the power dissipation capability of the PCB design
- Improving the thermal coupling of the component to the PCB by soldering the PowerPAD™
- Introducing airflow in the system

For more details on how to use the thermal parameters in the dissipation ratings table please check the [Thermal Characteristics Application Note \(SZZA017\)](#) and the [IC Package Thermal Metrics Application Note \(SPRA953\)](#).

TYPICAL APPLICATION

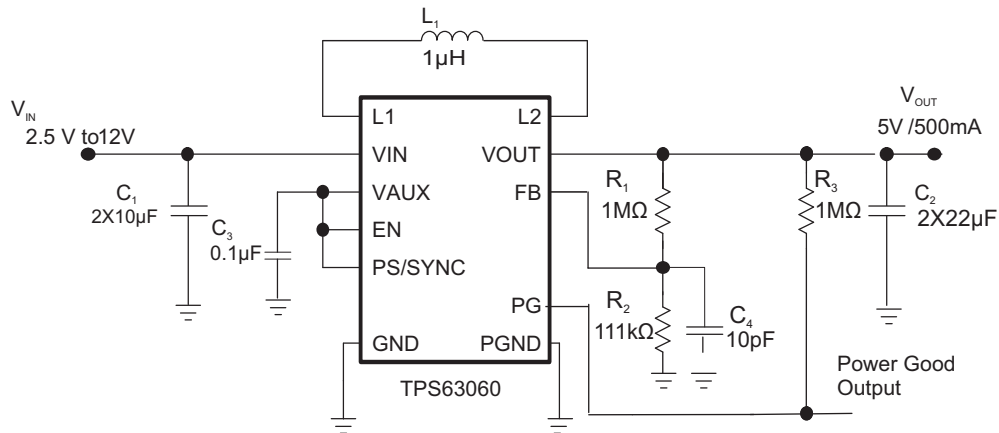

Figure 31. 5V and 500mA from 1 or 2 cell Li-Ion

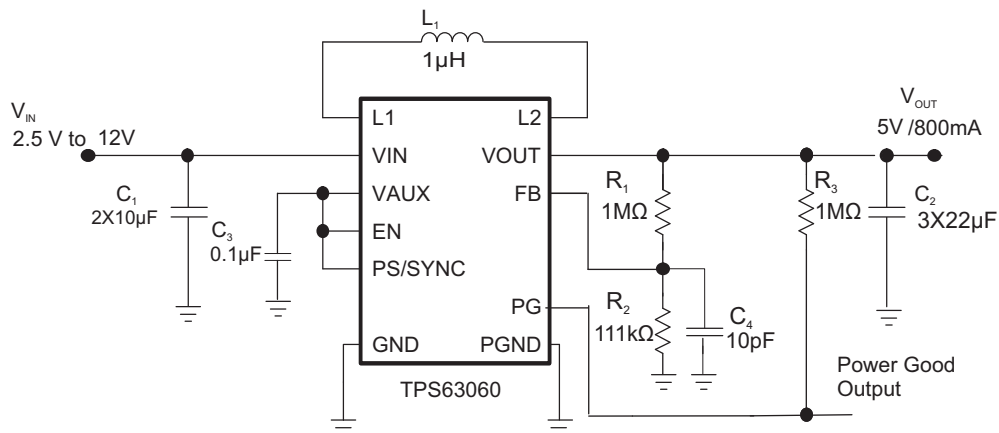

Figure 32. 5V and 800mA from Wide Input Supply range

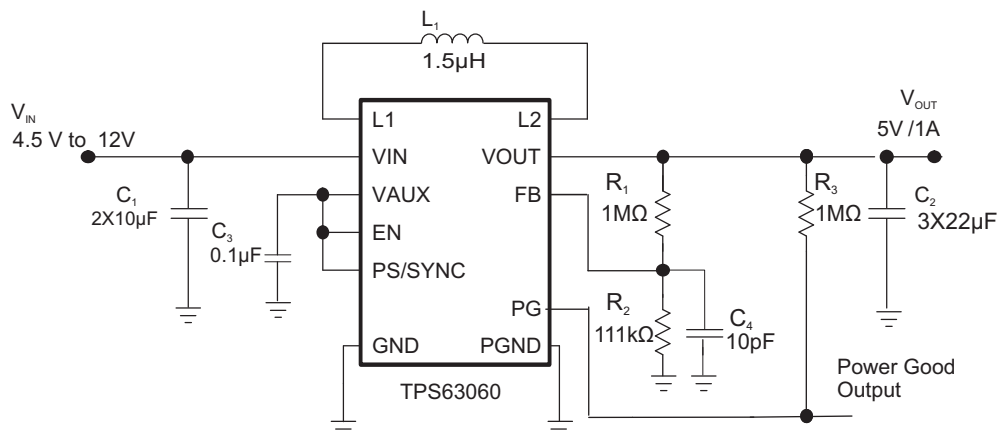

Figure 33. 5V and 1A from Input Voltage up to 12V

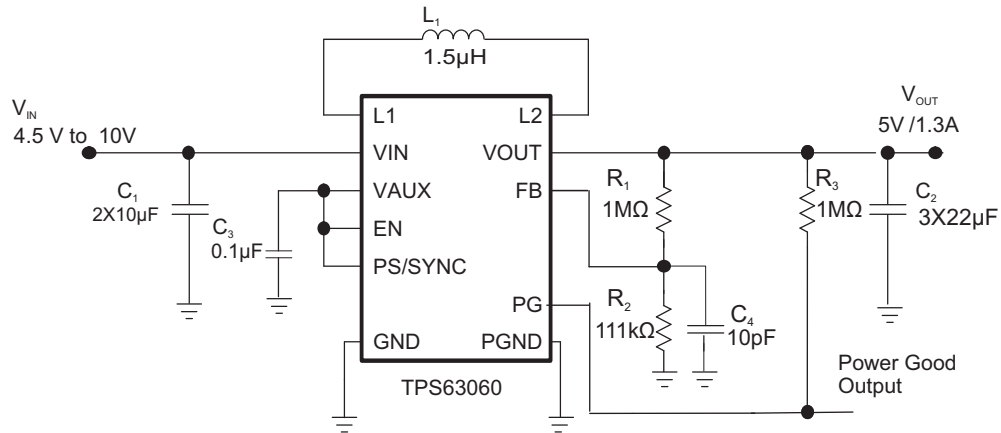

Figure 34. 5V and 1.3A from 2 cell Li-Ion

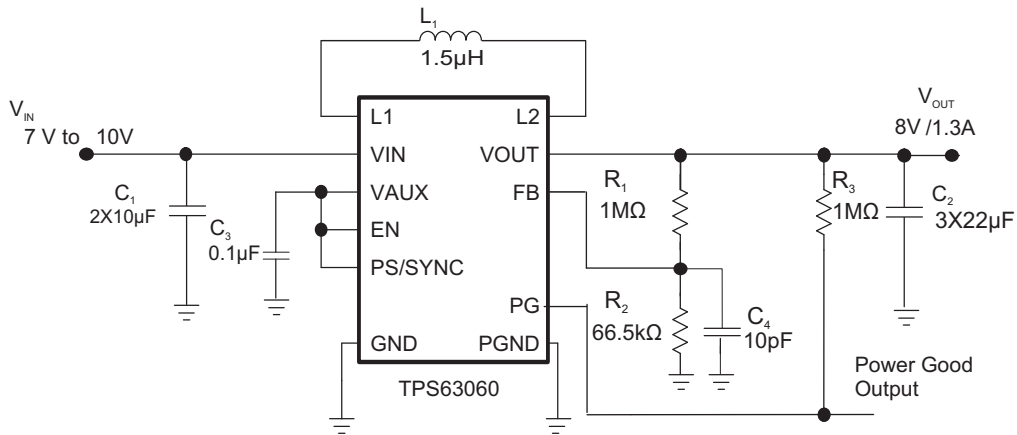

Figure 35. 8V and 1.3A from 2 cell Li-Ion

PACKAGING INFORMATION

Orderable Device	Status ⁽¹⁾	Package Type	Package Drawing	Pins	Package Qty	Eco Plan ⁽²⁾	Lead/ Ball Finish	MSL Peak Temp ⁽³⁾	Samples (Requires Login)
TPS63060DSCR	ACTIVE	SON	DSC	10	3000	Green (RoHS & no Sb/Br)	CU NIPDAU	Level-2-260C-1 YEAR	
TPS63060DSCT	ACTIVE	SON	DSC	10	250	Green (RoHS & no Sb/Br)	CU NIPDAU	Level-2-260C-1 YEAR	
TPS63061DSCR	ACTIVE	SON	DSC	10	3000	Green (RoHS & no Sb/Br)	CU NIPDAU	Level-2-260C-1 YEAR	
TPS63061DSCT	ACTIVE	SON	DSC	10	250	Green (RoHS & no Sb/Br)	CU NIPDAU	Level-2-260C-1 YEAR	

⁽¹⁾ The marketing status values are defined as follows:

ACTIVE: Product device recommended for new designs.

LIFEBUY: TI has announced that the device will be discontinued, and a lifetime-buy period is in effect.

NRND: Not recommended for new designs. Device is in production to support existing customers, but TI does not recommend using this part in a new design.

PREVIEW: Device has been announced but is not in production. Samples may or may not be available.

OBSOLETE: TI has discontinued the production of the device.

⁽²⁾ Eco Plan - The planned eco-friendly classification: Pb-Free (RoHS), Pb-Free (RoHS Exempt), or Green (RoHS & no Sb/Br) - please check <http://www.ti.com/productcontent> for the latest availability information and additional product content details.

TBD: The Pb-Free/Green conversion plan has not been defined.

Pb-Free (RoHS): TI's terms "Lead-Free" or "Pb-Free" mean semiconductor products that are compatible with the current RoHS requirements for all 6 substances, including the requirement that lead not exceed 0.1% by weight in homogeneous materials. Where designed to be soldered at high temperatures, TI Pb-Free products are suitable for use in specified lead-free processes.

Pb-Free (RoHS Exempt): This component has a RoHS exemption for either 1) lead-based flip-chip solder bumps used between the die and package, or 2) lead-based die adhesive used between the die and leadframe. The component is otherwise considered Pb-Free (RoHS compatible) as defined above.

Green (RoHS & no Sb/Br): TI defines "Green" to mean Pb-Free (RoHS compatible), and free of Bromine (Br) and Antimony (Sb) based flame retardants (Br or Sb do not exceed 0.1% by weight in homogeneous material)

⁽³⁾ MSL, Peak Temp. -- The Moisture Sensitivity Level rating according to the JEDEC industry standard classifications, and peak solder temperature.

Important Information and Disclaimer: The information provided on this page represents TI's knowledge and belief as of the date that it is provided. TI bases its knowledge and belief on information provided by third parties, and makes no representation or warranty as to the accuracy of such information. Efforts are underway to better integrate information from third parties. TI has taken and continues to take reasonable steps to provide representative and accurate information but may not have conducted destructive testing or chemical analysis on incoming materials and chemicals. TI and TI suppliers consider certain information to be proprietary, and thus CAS numbers and other limited information may not be available for release.

In no event shall TI's liability arising out of such information exceed the total purchase price of the TI part(s) at issue in this document sold by TI to Customer on an annual basis.

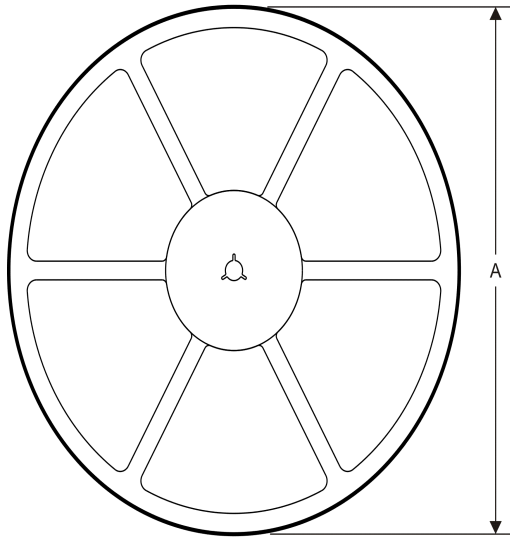
TAPE AND REEL INFORMATION
REEL DIMENSIONS

TAPE DIMENSIONS

A0	Dimension designed to accommodate the component width
B0	Dimension designed to accommodate the component length
K0	Dimension designed to accommodate the component thickness
W	Overall width of the carrier tape
P1	Pitch between successive cavity centers

TAPE AND REEL INFORMATION

*All dimensions are nominal

Device	Package Type	Package Drawing	Pins	SPQ	Reel Diameter (mm)	Reel Width W1 (mm)	A0 (mm)	B0 (mm)	K0 (mm)	P1 (mm)	W (mm)	Pin1 Quadrant
TPS63060DSCR	SON	DSC	10	3000	330.0	12.4	3.3	3.3	1.1	8.0	12.0	Q2
TPS63060DSCT	SON	DSC	10	250	180.0	12.4	3.3	3.3	1.1	8.0	12.0	Q2
TPS63061DSCR	SON	DSC	10	3000	330.0	12.4	3.3	3.3	1.1	8.0	12.0	Q2
TPS63061DSCT	SON	DSC	10	250	180.0	12.4	3.3	3.3	1.1	8.0	12.0	Q2

TAPE AND REEL BOX DIMENSIONS

*All dimensions are nominal

Device	Package Type	Package Drawing	Pins	SPQ	Length (mm)	Width (mm)	Height (mm)
TPS63060DSCR	SON	DSC	10	3000	346.0	346.0	29.0
TPS63060DSCT	SON	DSC	10	250	210.0	185.0	35.0
TPS63061DSCR	SON	DSC	10	3000	346.0	346.0	29.0
TPS63061DSCT	SON	DSC	10	250	210.0	185.0	35.0

DSC (S-PWSON-N10)

PLASTIC SMALL OUTLINE NO-LEAD

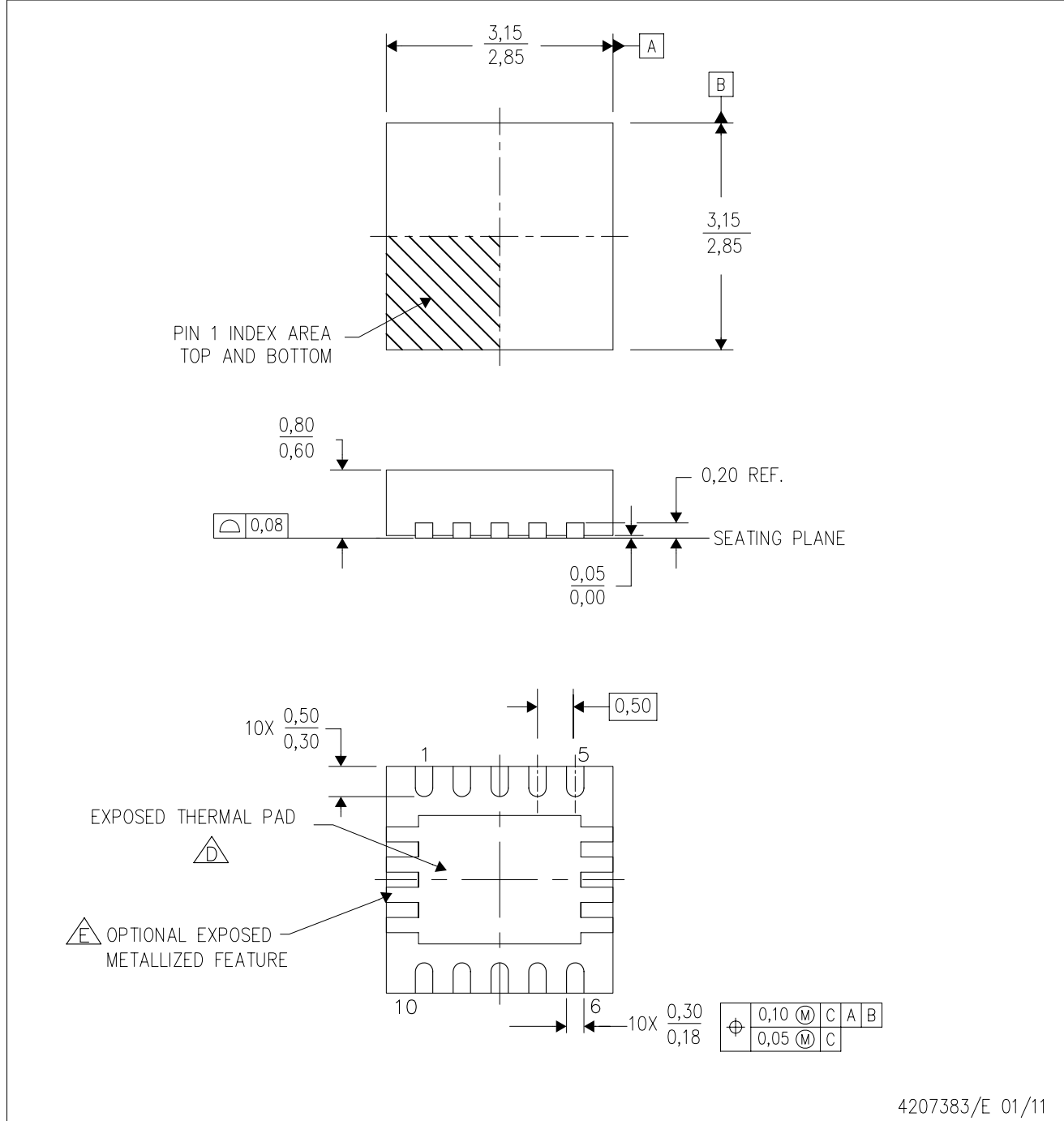

4207383/E 01/11

- NOTES:
- A. All linear dimensions are in millimeters. Dimensioning and tolerancing per ASME Y14.5M-1994.
 - B. This drawing is subject to change without notice.
 - C. Small Outline No-Lead (SON) package configuration.
 - D. The package thermal pad must be soldered to the board for thermal and mechanical performance.
 - E. See the Product Data Sheet for details regarding the exposed thermal pad features and dimensions.

THERMAL PAD MECHANICAL DATA

DSC (S-PWSON-N10)

PLASTIC SMALL OUTLINE NO-LEAD

THERMAL INFORMATION

This package incorporates an exposed thermal pad that is designed to be attached directly to an external heatsink. The thermal pad must be soldered directly to the printed circuit board (PCB). After soldering, the PCB can be used as a heatsink. In addition, through the use of thermal vias, the thermal pad can be attached directly to the appropriate copper plane shown in the electrical schematic for the device, or alternatively, can be attached to a special heatsink structure designed into the PCB. This design optimizes the heat transfer from the integrated circuit (IC).

For information on the Quad Flatpack No-Lead (QFN) package and its advantages, refer to Application Report, QFN/SON PCB Attachment, Texas Instruments Literature No. SLUA271. This document is available at www.ti.com.

The exposed thermal pad dimensions for this package are shown in the following illustration.

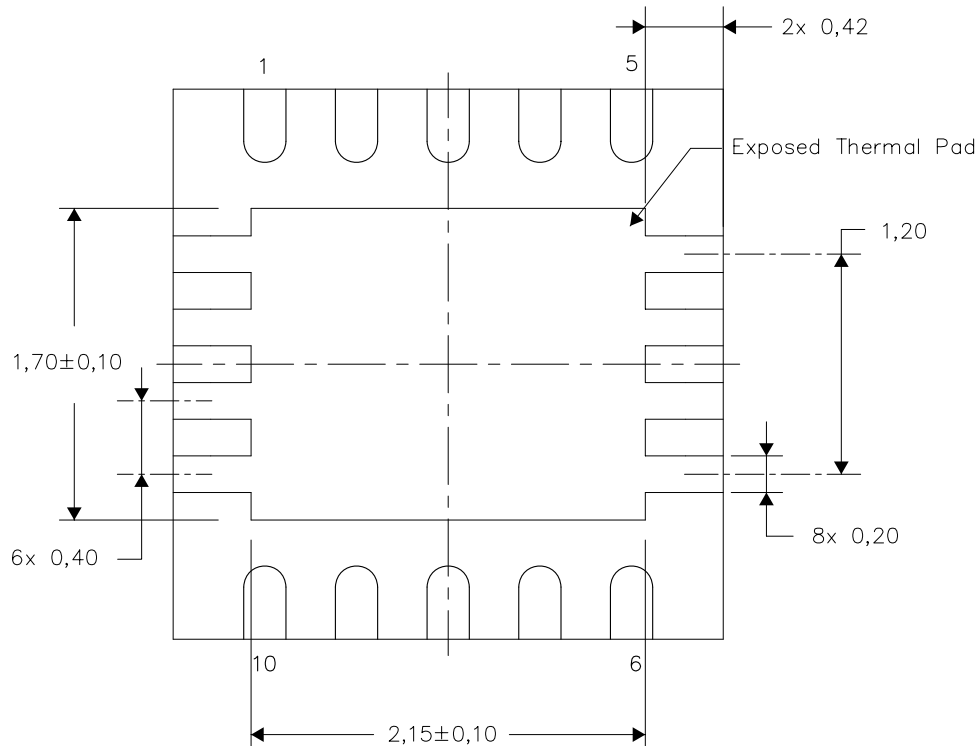

Bottom View

Exposed Thermal Pad Dimensions

4210391-5/F 04/11

NOTE: A. All linear dimensions are in millimeters

IMPORTANT NOTICE

Texas Instruments Incorporated and its subsidiaries (TI) reserve the right to make corrections, modifications, enhancements, improvements, and other changes to its products and services at any time and to discontinue any product or service without notice. Customers should obtain the latest relevant information before placing orders and should verify that such information is current and complete. All products are sold subject to TI's terms and conditions of sale supplied at the time of order acknowledgment.

TI warrants performance of its hardware products to the specifications applicable at the time of sale in accordance with TI's standard warranty. Testing and other quality control techniques are used to the extent TI deems necessary to support this warranty. Except where mandated by government requirements, testing of all parameters of each product is not necessarily performed.

TI assumes no liability for applications assistance or customer product design. Customers are responsible for their products and applications using TI components. To minimize the risks associated with customer products and applications, customers should provide adequate design and operating safeguards.

TI does not warrant or represent that any license, either express or implied, is granted under any TI patent right, copyright, mask work right, or other TI intellectual property right relating to any combination, machine, or process in which TI products or services are used. Information published by TI regarding third-party products or services does not constitute a license from TI to use such products or services or a warranty or endorsement thereof. Use of such information may require a license from a third party under the patents or other intellectual property of the third party, or a license from TI under the patents or other intellectual property of TI.

Reproduction of TI information in TI data books or data sheets is permissible only if reproduction is without alteration and is accompanied by all associated warranties, conditions, limitations, and notices. Reproduction of this information with alteration is an unfair and deceptive business practice. TI is not responsible or liable for such altered documentation. Information of third parties may be subject to additional restrictions.

Resale of TI products or services with statements different from or beyond the parameters stated by TI for that product or service voids all express and any implied warranties for the associated TI product or service and is an unfair and deceptive business practice. TI is not responsible or liable for any such statements.

TI products are not authorized for use in safety-critical applications (such as life support) where a failure of the TI product would reasonably be expected to cause severe personal injury or death, unless officers of the parties have executed an agreement specifically governing such use. Buyers represent that they have all necessary expertise in the safety and regulatory ramifications of their applications, and acknowledge and agree that they are solely responsible for all legal, regulatory and safety-related requirements concerning their products and any use of TI products in such safety-critical applications, notwithstanding any applications-related information or support that may be provided by TI. Further, Buyers must fully indemnify TI and its representatives against any damages arising out of the use of TI products in such safety-critical applications.

TI products are neither designed nor intended for use in military/aerospace applications or environments unless the TI products are specifically designated by TI as military-grade or "enhanced plastic." Only products designated by TI as military-grade meet military specifications. Buyers acknowledge and agree that any such use of TI products which TI has not designated as military-grade is solely at the Buyer's risk, and that they are solely responsible for compliance with all legal and regulatory requirements in connection with such use.

TI products are neither designed nor intended for use in automotive applications or environments unless the specific TI products are designated by TI as compliant with ISO/TS 16949 requirements. Buyers acknowledge and agree that, if they use any non-designated products in automotive applications, TI will not be responsible for any failure to meet such requirements.

Following are URLs where you can obtain information on other Texas Instruments products and application solutions:

Products

Audio	www.ti.com/audio
Amplifiers	amplifier.ti.com
Data Converters	dataconverter.ti.com
DLP® Products	www.dlp.com
DSP	dsp.ti.com
Clocks and Timers	www.ti.com/clocks
Interface	interface.ti.com
Logic	logic.ti.com
Power Mgmt	power.ti.com
Microcontrollers	microcontroller.ti.com
RFID	www.ti-rfid.com
OMAP Mobile Processors	www.ti.com/omap
Wireless Connectivity	www.ti.com/wirelessconnectivity

Applications

Communications and Telecom	www.ti.com/communications
Computers and Peripherals	www.ti.com/computers
Consumer Electronics	www.ti.com/consumer-apps
Energy and Lighting	www.ti.com/energy
Industrial	www.ti.com/industrial
Medical	www.ti.com/medical
Security	www.ti.com/security
Space, Avionics and Defense	www.ti.com/space-avionics-defense
Transportation and Automotive	www.ti.com/automotive
Video and Imaging	www.ti.com/video

TI E2E Community Home Page

e2e.ti.com

Mailing Address: Texas Instruments, Post Office Box 655303, Dallas, Texas 75265
Copyright © 2011, Texas Instruments Incorporated